

DSIE 2B19

12NC: 869991616350

GTIN (EAN) code: 8050147557983

 **INDESIT**
Life proof.

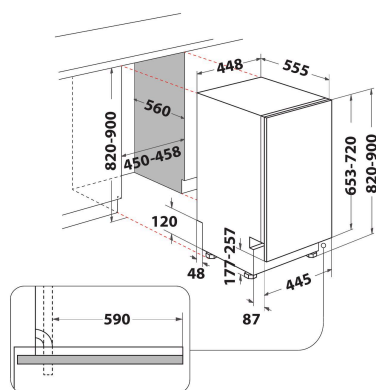

MAIN FEATURES

Construction type	Vstavaná
Installation type	Plne vstavaná
Type of control	Electronic
Type of control settings	-
Removable work top	Nie
Main colour of product	White
Electrical connection rating (W)	1900
Current (A)	10
Voltage (V)	220-230
Frequency (Hz)	50
Length of Electrical Supply Cord (cm)	130
Plug type	Schuko
Length inlet hose (cm)	155
Length outlet hose (cm)	150
Adjustable feet	Yes - all from front
Height of the product	820
Width of the product	448
Depth of the product	555
Minimum niche height	820
Maximum niche height	900
Minimum niche width	450
Maximum niche width	600
Niche depth	560
Net weight (kg)	27.2
Gross weight (kg)	29

TECHNICAL FEATURES

Automatic programmes	Nie
Maximum temperature for water intake (°C)	60
Start delay options	No delay
Start delay time max. (h)	0
Progress indicator	-
change to:	Nie
Salt light indicator	Nie
Rinse aid light indicator	Nie
Safety device	Áno
Adjustable upper basket	Áno
Largest loadable dish upper basket (cm)	0
Largest loadable dish lower basket (cm)	0
Maximum number of place settings (EU 2017/1369)	10
Column installation	Nie

ENERGETICKÝ ŠTÍTK

Energy Efficiency Class (Regulation (EU) 2017/1369)	F
Energy Consumption for 100 cycles Eco Programme (EU 2017/1369)	84
Power consumption in standby mode (Psm) (EU 2017/1369)	0,50
Power consumption in off-mode (Po) (EU 2017/1369)	0,00
The water consumption of the eco programme in liters per cycle (EU 2017/1369)	11,5
Airborne acoustical noise emissions (EU 2017/1369)	49
Airborne acoustical noise emission class (EU 2017/1369)	C
Programme duration in HMM (EU 2017/1369)	4:00